

Modular Cooking Range Line thermaline 80 - 4 Zone Induction Top on Warming Cabinet, 1 Side H=800

ITEM # _____

MODEL # _____

NAME # _____

SIS # _____

AIA # _____

588436 (MAIQFAH4AO)

Induction Top, 4 zones, one-side operated on Warming Cabinet

Short Form Specification

Item No.

Unit constructed according to DIN 18860_2 with 20 mm drop nose top. Internal frame for heavy duty sturdiness in stainless steel. 2 mm top in 1.4301 (AISI 304). Flat surface construction, easily cleanable. THERMODUL connection system enables seamless worktop when units are connected and avoids soil penetrating. Smooth glass ceramic surface without any "dead" spots allows for quick and easy cleaning. Features 9 power levels with fast deployment to full heating power and very low heat dissipation to the kitchen. Overheat protection switches off the supply in case of overheating. Metal knobs with embedded hygienic silicon "soft" grip enable easier handling and cleaning. 800 mm wide warming cabinet with 2 doors, constructed according to DIN 18860_2 with 70 mm recessed plinth. Internal frame for heavy duty sturdiness in stainless steel. 2 mm top in 1.4301 (AISI 304). Flat surface construction, easily cleanable. THERMODUL connection system enables seamless worktop when units are connected and avoids soil penetrating. Temperature in the cabinet can be set through thermostat, up to a maximum of 110 °C. Cabinet storage space accepts GN 1/1 containers. IPX5 water resistant certification.

Main Features

- Fast deployment with full heating power immediately.
- Low heat dissipation to the kitchen.
- Overheat protection: a temperature sensor switches off the supply in case of overheating.
- Pans can easily be moved from one area to another without lifting.
- The smooth glass-ceramic surface can be quickly and easily cleaned, thus providing maximum hygiene.
- All major components may be easily accessed from the front.
- THERMODUL connection system creates a seamless work top when units are connected to each other thus avoiding soil penetrating vital components and facilitating the removal of units in case of replacement or service.
- Metal knobs with embedded hygienic silicon "soft" grip for easier handling and cleaning. The special design of the controls prevent infiltration of liquids or soil into vital components.
- 9 power levels.
- Large visible digital display manufactured in tempered glass to resist heat and chemicals, showing temperatures or power settings. The display also shows on/off status of the appliance and on/off status of the heating elements.
- Unit constructed according to DIN 18860_2 with 70 mm recessed plinth.
- Temperature in the cupboard can be set through a thermostat to suit different requirements. The maximum temperature is 110°C.

Construction

- Control light for each zone.
- 2 mm top in 1.4301 (AISI 304).
- Flat surface construction with minimal hidden areas to easily clean all surfaces
- Unit constructed according to DIN 18860_2 with 20 mm drop nose top.
- Unit constructed according to DIN 18860_2 with 20 mm drop nose top and 70 mm recessed plinth.
- IPX5 water resistance certification.
- Storage space in the base of the appliance accepts GN1/1 containers.
- Internal frame for heavy duty sturdiness in stainless steel.

Sustainability

- This model is compliant with Swiss Energy



APPROVAL: _____

Efficiency Ordinance (730.02).



Optional Accessories

- | | | | | | |
|--|------------|--------------------------|---|------------|--------------------------|
| • Scraper for cook tops | PNC 910601 | <input type="checkbox"/> | • Side reinforced panel only in combination with side shelf, for freestanding units | PNC 913257 | <input type="checkbox"/> |
| • Connecting rail kit, 800mm | PNC 912500 | <input type="checkbox"/> | • Side reinforced panel only in combination with side shelf, for back-to-back installations, left | PNC 913273 | <input type="checkbox"/> |
| • Stainless steel side panel, 800x800mm, freestanding | PNC 912508 | <input type="checkbox"/> | • Side reinforced panel only in combination with side shelf, for back-to-back installation, right | PNC 913274 | <input type="checkbox"/> |
| • Portioning shelf, 800mm width | PNC 912526 | <input type="checkbox"/> | • Shelf fixation for TL80-85-90 one-side operated, TL80 two-side operated | PNC 913281 | <input type="checkbox"/> |
| • Portioning shelf, 800mm width | PNC 912556 | <input type="checkbox"/> | • Filter W=800mm | PNC 913665 | <input type="checkbox"/> |
| • Folding shelf, 300x800mm | PNC 912577 | <input type="checkbox"/> | • Stainless steel dividing panel, 800x800mm, (it should only be used between Electrolux Professional thermaline Modular 80 and thermaline C80) | PNC 913669 | <input type="checkbox"/> |
| • Folding shelf, 400x800mm | PNC 912578 | <input type="checkbox"/> | • Electric mains switch 63A 10mm ² NM for modular H800 electric units (factory fitted) | PNC 913677 | <input type="checkbox"/> |
| • Fixed side shelf, 200x800mm | PNC 912583 | <input type="checkbox"/> | • Stainless steel side panel, 800x800mm, flush-fitting (it should only be used against the wall, against a niche and in between Electrolux Professional thermaline and ProThermetic appliances and external appliances - provided that these have at least the same dimensions) | PNC 913685 | <input type="checkbox"/> |
| • Fixed side shelf, 300x800mm | PNC 912584 | <input type="checkbox"/> | | | |
| • Fixed side shelf, 400x800mm | PNC 912585 | <input type="checkbox"/> | | | |
| • Stainless steel front kicking strip, 800mm width | PNC 912598 | <input type="checkbox"/> | | | |
| • Stainless steel side kicking strips left and right, freestanding, 800mm width | PNC 912619 | <input type="checkbox"/> | | | |
| • Stainless steel side kicking strips left and right, back-to-back, 1610mm width | PNC 912625 | <input type="checkbox"/> | | | |
| • Stainless steel plinth, freestanding, 800mm width | PNC 912825 | <input type="checkbox"/> | | | |
| • Connecting rail kit: modular 80 (on the left) to ProThermetic tilting (on the right), ProThermetic stationary (on the left) to ProThermetic (on the right) | PNC 912971 | <input type="checkbox"/> | | | |
| • Connecting rail kit: modular 80 (on the right) to ProThermetic tilting (on the left), ProThermetic stationary (on the right) to ProThermetic (on the left) | PNC 912972 | <input type="checkbox"/> | | | |
| • Endrail kit, flush-fitting, left | PNC 913109 | <input type="checkbox"/> | | | |
| • Endrail kit, flush-fitting, right | PNC 913110 | <input type="checkbox"/> | | | |
| • Endrail kit (12.5mm) for thermaline 80 units, left | PNC 913200 | <input type="checkbox"/> | | | |
| • Endrail kit (12.5mm) for thermaline 80 units, right | PNC 913201 | <input type="checkbox"/> | | | |
| • Stainless steel side panel, left, h=800 | PNC 913216 | <input type="checkbox"/> | | | |
| • Stainless steel side panel, right, h=800 | PNC 913217 | <input type="checkbox"/> | | | |
| • T-connection rail for back-to-back installations without backsplash | PNC 913227 | <input type="checkbox"/> | | | |
| • Insert profile D=800mm | PNC 913230 | <input type="checkbox"/> | | | |
| • Perforated shelf for warming cabinets and cupboard bases (one-side operated TL80-85-90 and two-side operated for TL80) | PNC 913234 | <input type="checkbox"/> | | | |
| • Endrail kit, (12.5mm), for back-to-back installation, left | PNC 913249 | <input type="checkbox"/> | | | |
| • Endrail kit, (12.5mm), for back-to-back installation, right | PNC 913250 | <input type="checkbox"/> | | | |
| • Endrail kit, flush-fitting, for back-to-back installation, left | PNC 913253 | <input type="checkbox"/> | | | |
| • Endrail kit, flush-fitting, for back-to-back installation, right | PNC 913254 | <input type="checkbox"/> | | | |

Front

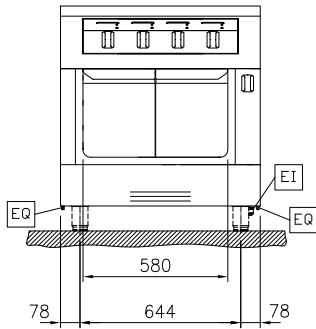

Side

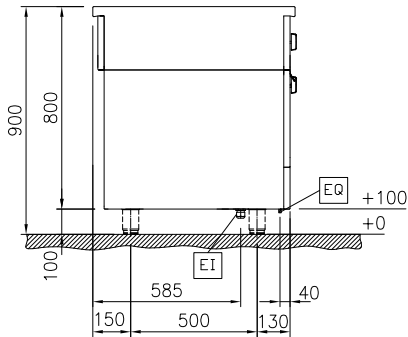

EI = Electrical inlet (power)
 EQ = Equipotential screw

Top

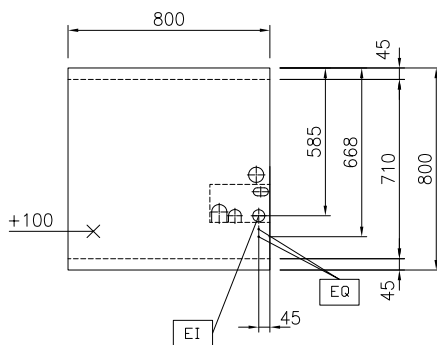

Electric

Supply voltage:

588436 (MAIQFAH4AO) 400 V/3N ph/50/60 Hz

Total Watts:

22 kW

Key Information:

Configuration: On Oven, One-Side Operated

Front Plates Power: 5 - 5 kW

Back Plates Power: 5 - 5 kW

Front Plates dimensions: 320x330 320x330

Back Plates dimensions: 320x330 320x330

Induction Top Dimensions (width): 800 mm

Induction Top Dimensions (depth): 800 mm

External dimensions, Width: 800 mm

External dimensions, Depth: 800 mm

External dimensions, Height: 800 mm

Net weight: 72 kg

Sustainability

Current consumption: 35.6 Amps